

Capital Projects Update

Presented by Lisa Coleman



Preview

Overview of Projects in Planning/Design/Construction

- 2025: projects completed + bids to date
- Project highlights



Planning

Treatment Plant

- Heat and Power Improvements (Facility Plan)
- Biosolids Facility Plan

Interceptors

- WI Rehab- Babcock to Dayton Street (C2027)
- WI Rehab-Farley to Marshall (C2027)
- West Interceptor on Regent St (Park to E. Campus Mall) (C2028)
- NEI – Truax Extension Rehab

Pumping Stations & Force Mains

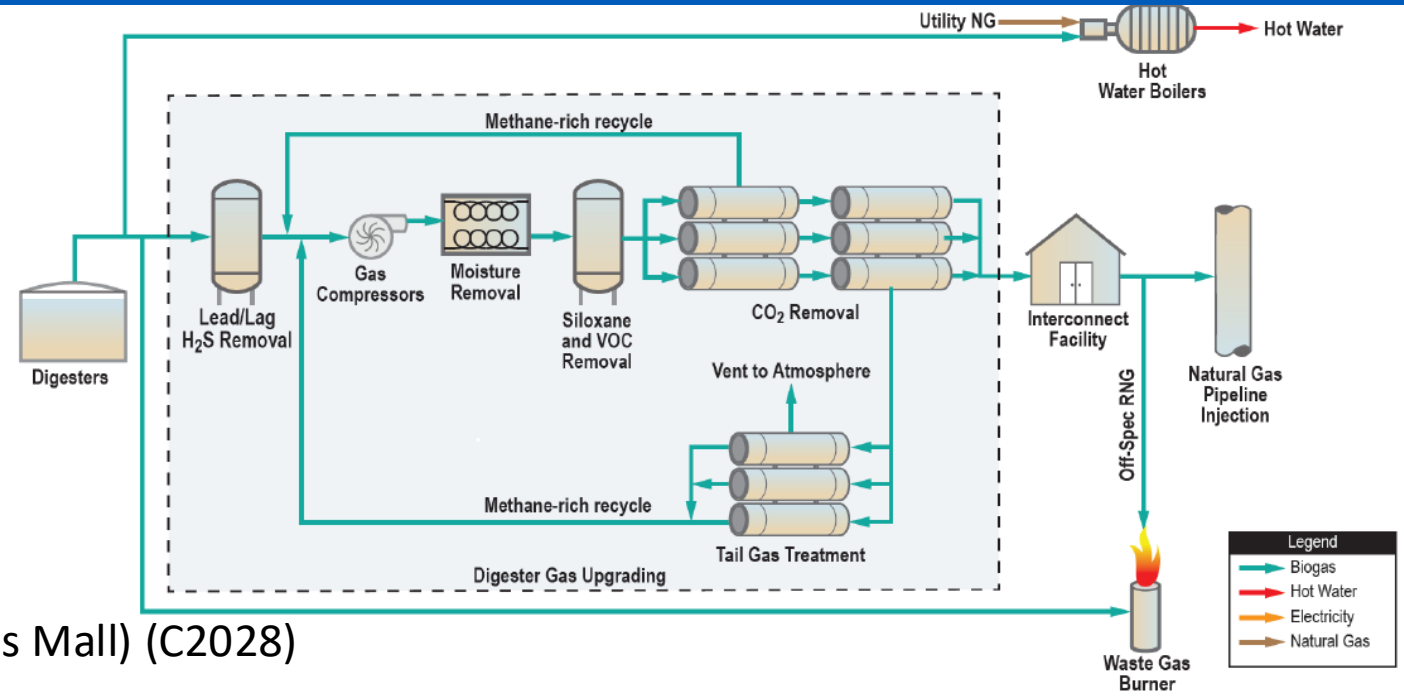

In design

Treatment Plant

- Liquid Processing Phase 2 (bundled...)
- Lagoon Dike Improvements
- Dryer and Seeding Modifications

Interceptors

- Manhole Rehabilitation - Old West Interceptor
- NSVI Capacity Improvements (Phase 1)
- NSVI Capacity Improvements (Phase 2)
- Southeast Interceptor Relocation at Yahara River

Pumping Stations & Force Mains

- Pumping Station Bar Screens
- Crosstown Force Main Air Release
Valve Saddle Tap Replacements (C2026)

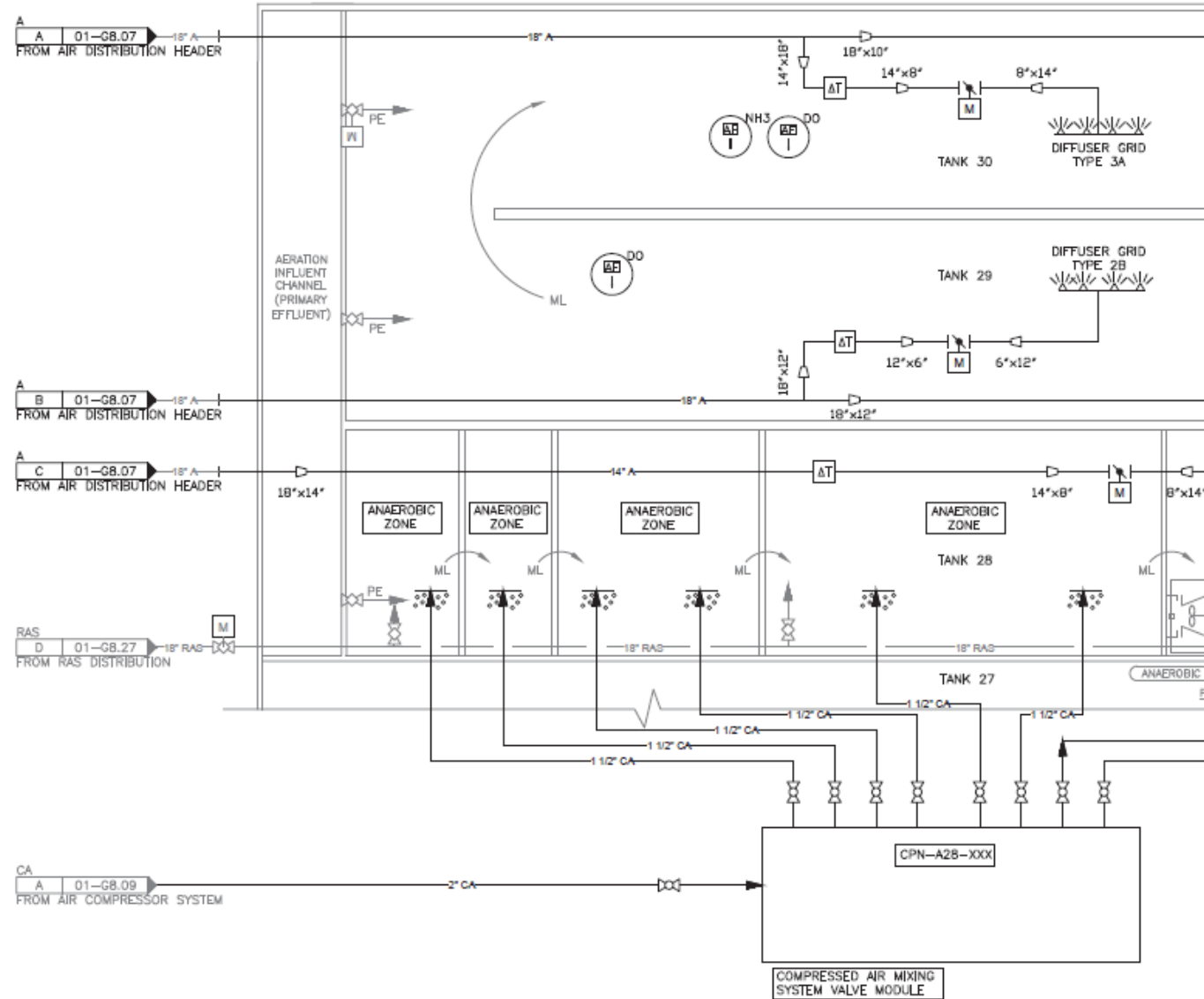

Current Construction Projects

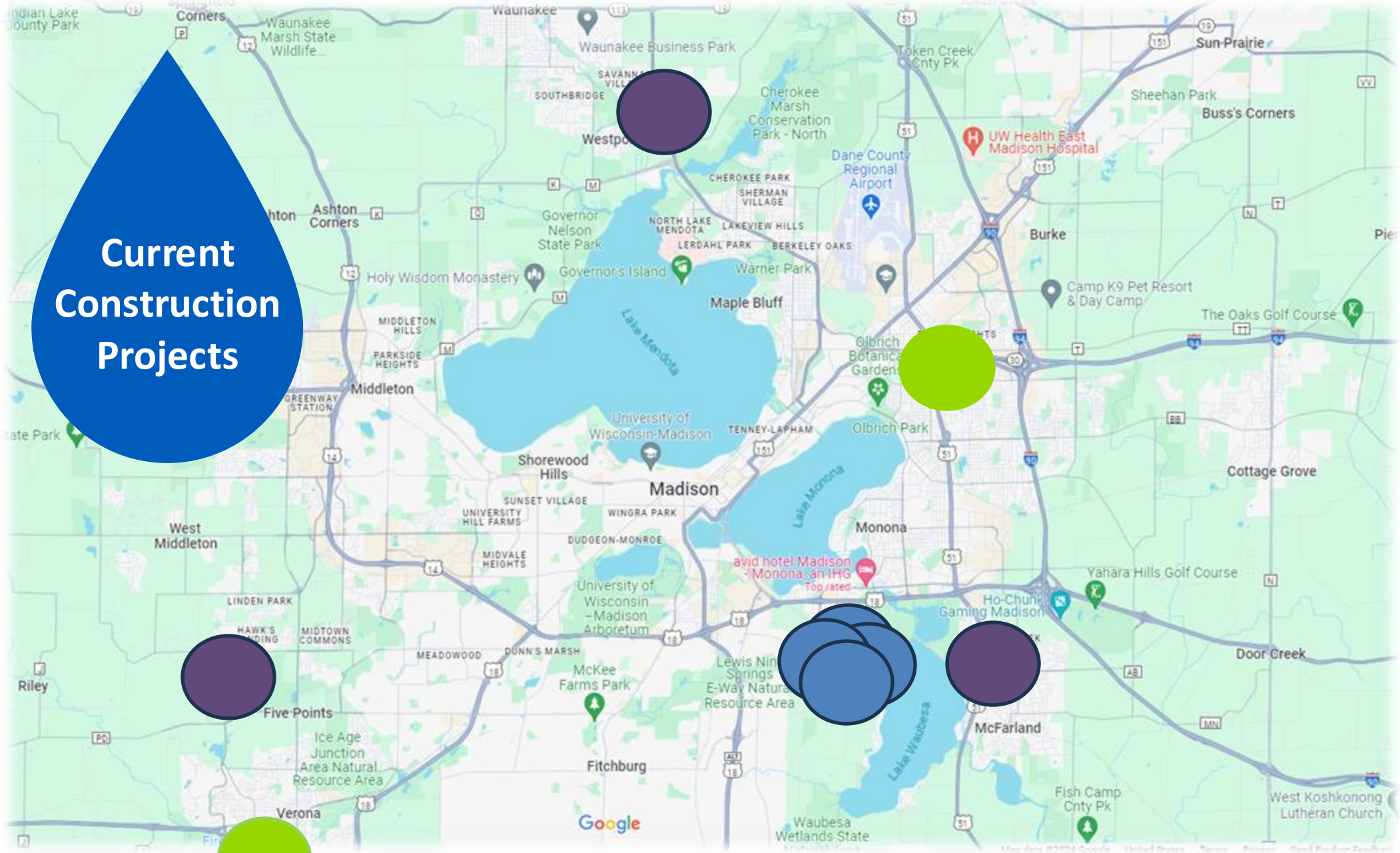

Under construction

Treatment Plant

- Sludge Thickeners 1 and 2 Drive Replacement
- Electrical Service Equipment Replacement
- Flow Splitter Improvements
- *W4 System Improvements – bids due 10/21/25*

Interceptors

- Lower Badger Mill Creek Interceptor – Phase 6
- NEI – Waunakee Extension Capacity Improvements (Phase 1)
- Southeast Interceptor Rehabilitation on USH 51(Phase 1)

Pumping Stations and Force Mains

- Pumping Station 17 Firm Capacity Improvements
- Pumping Station 10 Force Main

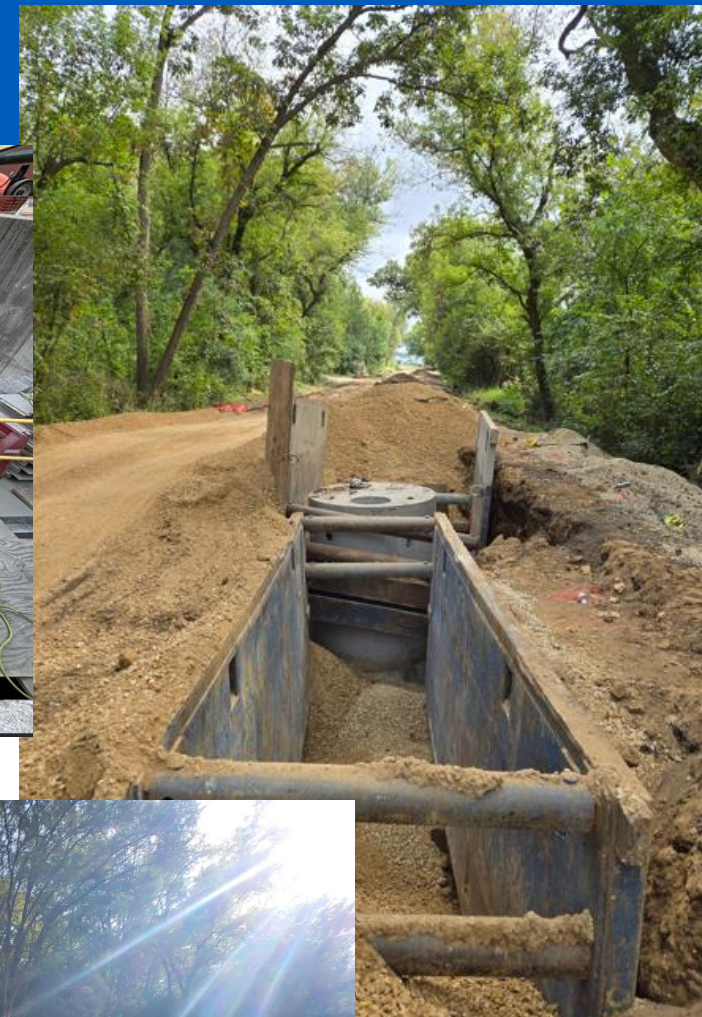

Projects completed in 2025 (so far...)

Treatment Plant

2021 Treatment Plant HVAC Improvement Project

Interceptors

West Interceptor Rehab - Segoe Road to Shorewood Boulevard – Substantially complete

West Interceptor Shorewood Relief Ph 3 – substantially complete

Pumping Stations and Force Mains

Pumping Station 17 Force Main Relief Ph 2 -
~substantially complete

Pumping Station 4 Rehabilitation ~substantially complete



2025 Bids (so far...)

West Interceptor Rehab – Segoe Road to Shorewood Blvd

- Bid Cost \$895,000 (Visu-Sewer)

Lower Badger Mill Creek Interceptor – Phase 6

- Bid Cost \$3,445,000 (Integrity)

Pumping Station 10 Force Main

- Bid Cost \$1,782,500 (Terra)





Project Highlights

Madison Metropolitan
Sewerage District



WI Shorewood Relief Ph 3

Scope

Last phase of the capacity upgrade project

Schedule and Status

- Ph 1 began construction in early 2021
- Ph 3 began June 2024
- Substantial completion 8/2025
(early completion of special traffic control phases)
- “Thank you” from UW Hospital

Contractor

Speedway Sand and Gravel Inc.

Budget

Total Project Cost: \$8.5M

Construction Contract \$7.1M (w/ 5 COs)

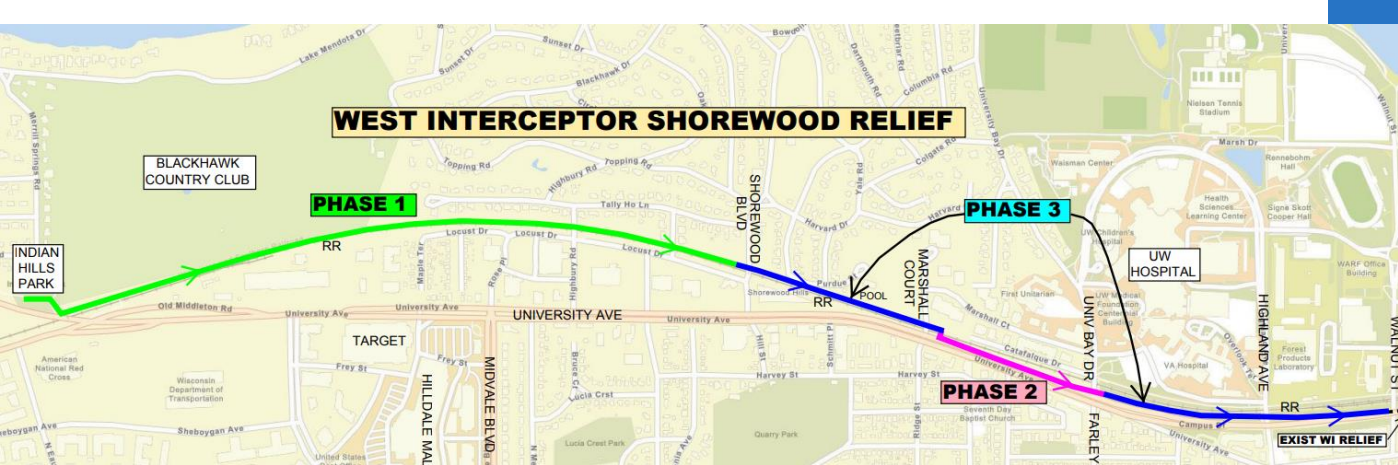

WI Rehab - Segoe Rd to Shorewood Blvd

Scope

Rehab 90+ year old sewer. Line sewer + MHs

Schedule and Status

- Construction over summer 2025
- Substantial completion 8/2025
- 8 phases to allow traffic control setups to only be in place overnight (no daytime lane closures)

Contractor

Visusewer

Budget

Total Project Cost: \$1.35M

Construction Contract \$906K (3 COs)

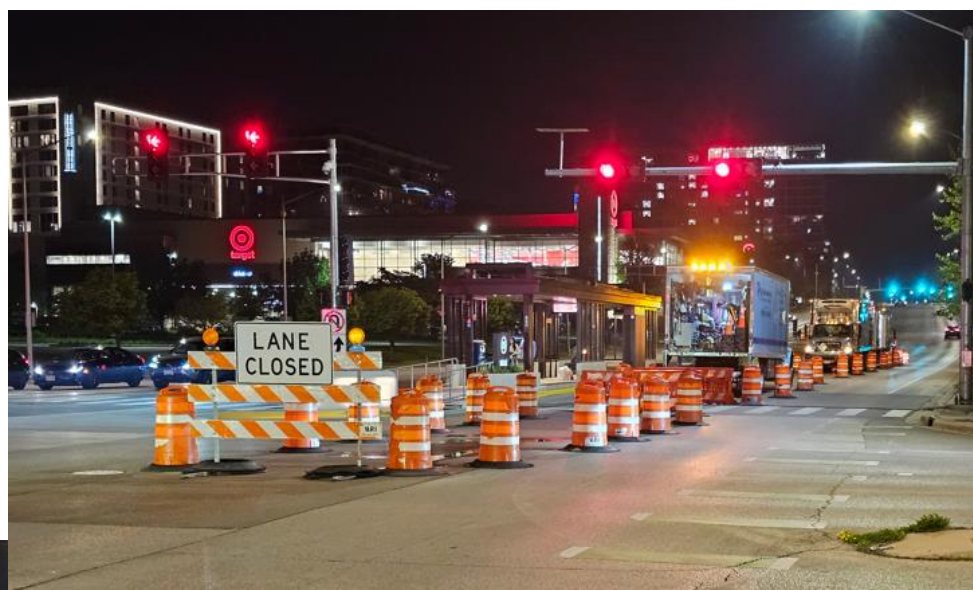

Questions?

Madison Metropolitan
Sewerage District

Madison Metropolitan Sewerage District

Madison Metropolitan
Sewerage District